



SERVICE OFFICE  
The Dometic Corp.

**Fabric Roller Tube Assembly with  
Square 1™ Hardware**

1

**OPERATING INSTRUCTIONS**

**MODEL 8300  
Sunchaser**

# TO OPEN Index

1. Loosen the rafter adjustment lock knobs (located behind the main arm) and unhook the travel straps. (FIG. 1)

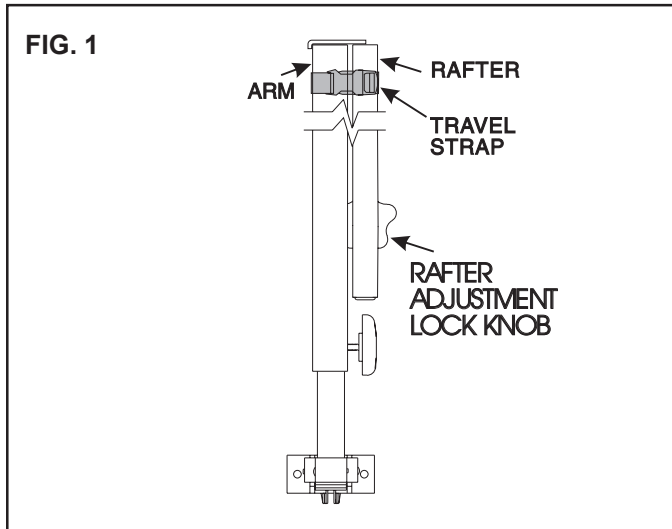

2. Locate Safe-T-Lock™ Lever on the right end cap of the fabric roller tube assembly. Place the hook of the pull rod behind lock lever and pull lever forward into the ROLL DOWN position. (FIG. 2)

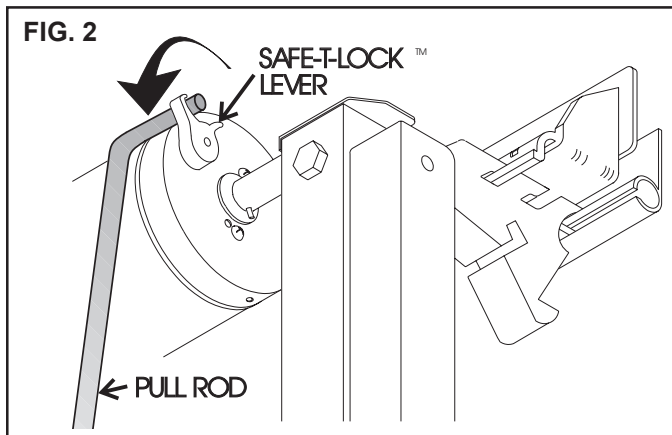

3. Insert hook of the pull rod through the loop of the pull strap. Pull the strap outward and completely extend the awning. The awning will stay positioned by itself. (FIG. 3)

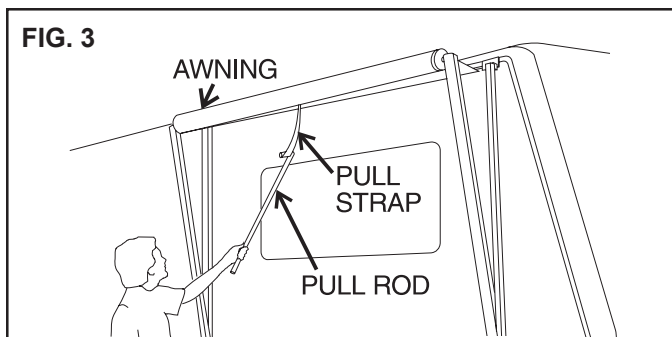

4. From the side of either arm assembly, pull sideways on the rafter and slide it to the top of the support arm. Place downward force on main support arm to remove slack from fabric and tighten black adjustment knob on the rafter arm. Repeat for other side. (FIG. 4)

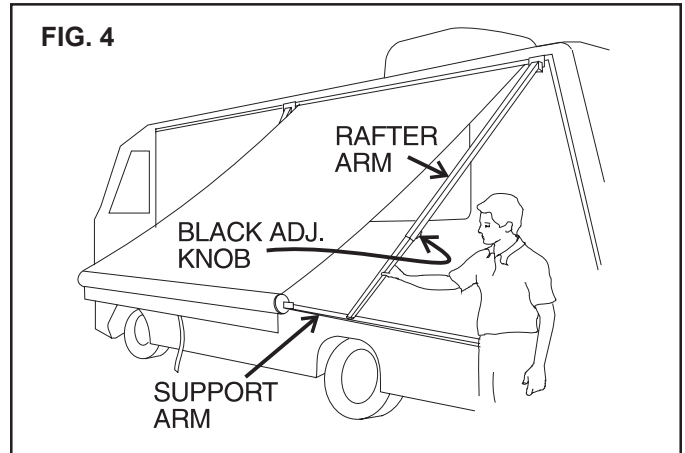

5. Reposition the pull strap out of the way by sliding it down the fabric roller tube assembly toward the right (same end as the Safe-T-Lock™). Wrap the strap around the main support arm. (FIGS. 5A & 5B)

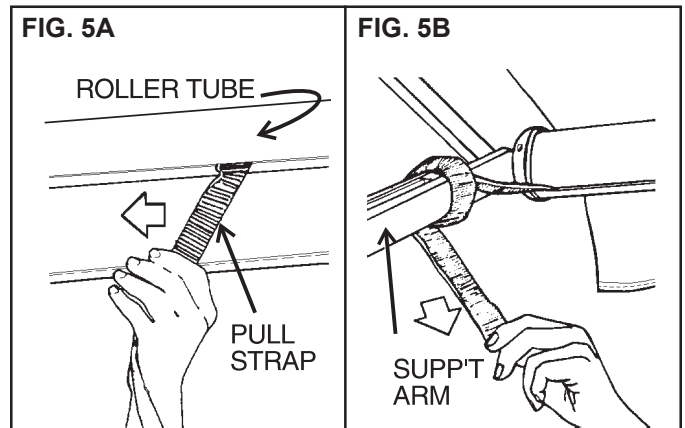

6. To raise awning, grasp arm, loosen knob, and lift the arm assembly. When the desired awning height is reached, retighten the knob. Extend other arm assembly to the same height. (FIG. 6)

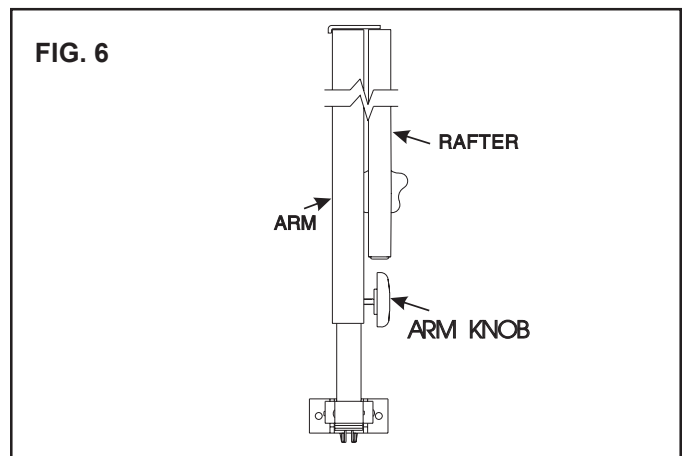

7. For extended stays and where ground and weather conditions permit, the patio position allows easier access and more usable space (FIG. 7B):

Lower the awning (reverse Steps in Sec. 6)

Grasp the arm and support the awning weight. Push on the thumb latch and remove the foot from the bracket. (FIG. 7A)

Place the support arm down vertically on the ground and adjust the support arm height. (FIG. 7B)

Accessory hold-down stakes should be installed through the holes on the awning foot to secure the awning in case of wind. (FIG. 7C)

8. **CAUTION: Whenever heavy or prolonged rain or wind is anticipated, or you will leave the awning unattended, it is best to close the awning. Damage as a result of weather is not covered by warranty.**

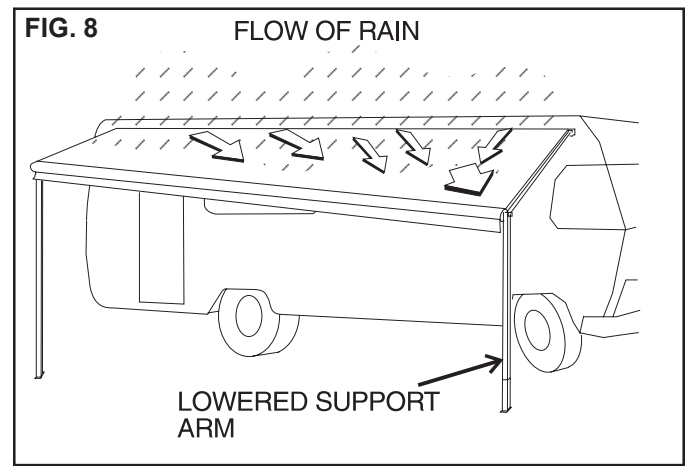

## TO CLOSE

1. **FROM PATIO POSITION**

Remove the stakes from the awning foot and swing the support arm up to the bottom mounting bracket. Repeat on other side.

(FIG. 1)

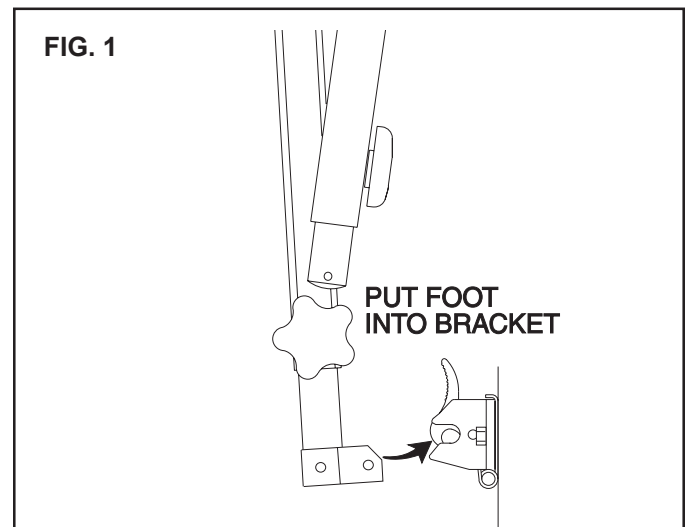

2. **FROM VEHICLE MOUNTING POSITION:** Grasp the main arm, loosen the arm knob and lower main support arm down to the stop plug. (FIG. 2)

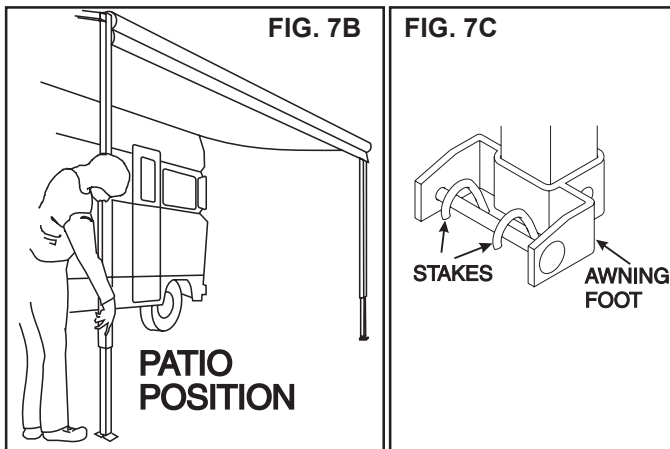
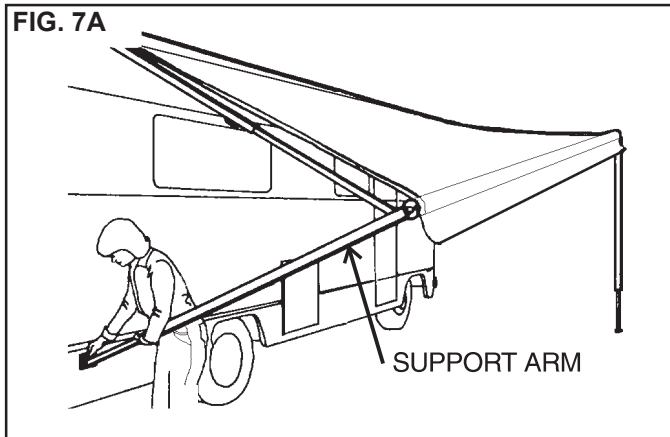
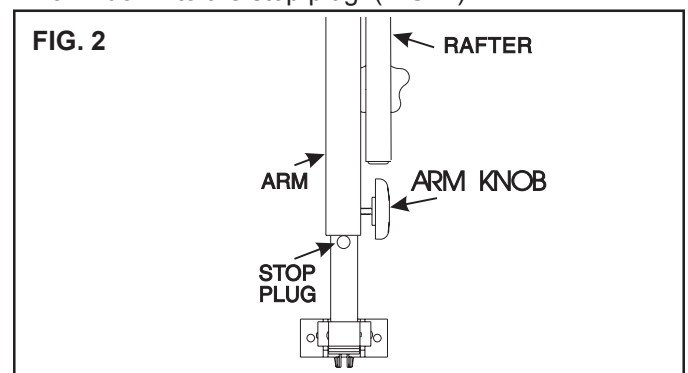

**CAUTION: DO NOT DRIVE THE STAKES "HOME" AS IT WILL BE DIFFICULT TO PULL THEM OUT AND MAY DAMAGE THE AWNING FOOT.**

Repeat this step on the other side to complete the patio position setup.

- To release the rafter arm, loosen black adjustment knob on the rafter arm and lift up on the slider catch, located under the slider. Pull sideways on the rafter and slide it to the bottom of the main arm. **DO NOT** retighten adjustment knob at this time. (FIG. 3)

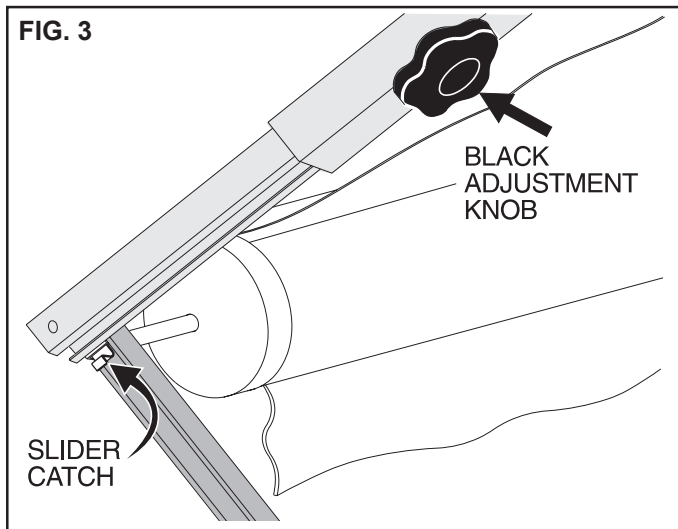

- Tighten the four adjustment knobs and secure the travel straps.

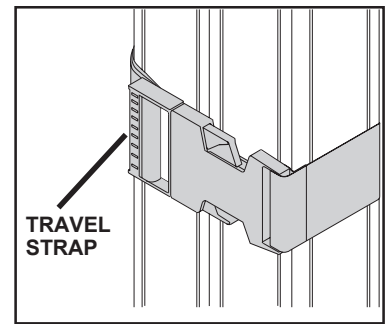

The awning is now ready for travel.

- Prepare fabric roller tube assembly for roll-up. While pulling down on the pull strap or while, from the bottom, turning the entire roller tube toward you slightly, flip the Safe-T-Lock™ Lever into the ROLL UP position.

**CAUTION: DO NOT release the awning as it is now under tension and could snap back against the vehicle side.**

Hold the roller tube down and slide the pull strap to the middle of awning. Using strap for control of speed and even roll-up, allow awning to return to the vehicle side. (FIG. 4)

**NOTE:** Wind the strap diagonally as the awning rolls up to avoid creating a bulge and stretching the awning fabric.

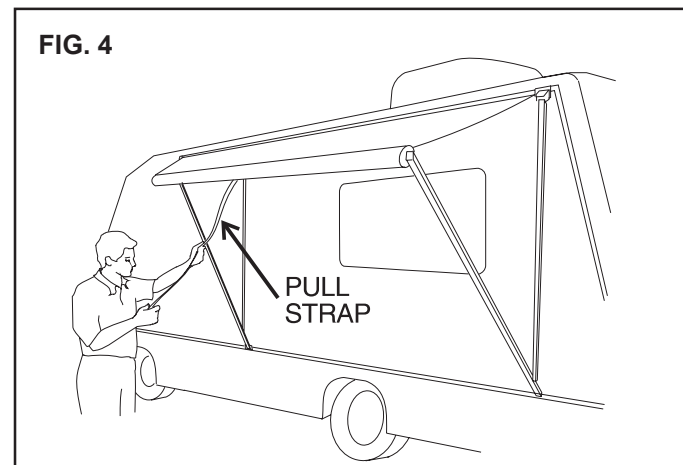

## HELPFUL HINTS FOR AWNING CARE

- Whenever the awning is wet while rolled up, as soon as conditions allow, roll it out and let it dry before rolling it up again. This will help prevent mildew and rotting.
- Always make sure the awning is extended high enough before opening entry door.
- **WHEN TO GET MORE HELP:**  
If malfunctions occur that cannot be corrected by reviewing this user's guide, contact a qualified Dometic service technician.

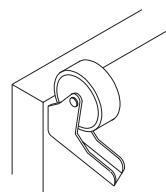

**Please note:** A slight "travel line" may appear where the door roller contacts the awning fabric. This is considered normal and does not affect the integrity of the awning.