

This program will address the most common system problems associated with the A&E Patio Awnings supplied by The Dometic Corporation. Our intent is to provide you with a guideline of checks to make, should you encounter one of the following symptoms.

SYMPTOM	CAUSE	REFER TO
1. Black adjustment knob will not tighten	Nutsert Washer Stack-up	1.1 1.2
2. Fabric leaks at the roller tube	Stitches	2.10
3. Main support arms will not extend	Push button assembly Adjustable arm assembly	1.3 1.4
4. Awning has bulges or wrinkles where pull strap rolls up	Operation	3.1
5. Awning fabric will not roll up straight	Fabric position Out of square	2.1 2.2
6. Weatherguard wrinkled	Seams Vehicle sidewall Tek screws Weatherguard Out of square	2.4 4.2 2.12 2.3 2.2
7. Fabric does not hang well	Out of square Tube deflection Tek screws Seams Vehicle sidewall Stitches	2.2 2.6 2.12 2.4 4.2 2.10
8. Must lift main arm(s) to open or close the awning	Stop plug Bottom mounting brackets	1.7 1.6
9. Awning arm(s) stay up against side of coach when trying to open awning	Top mounting bracket Fabric position Operation Travel lock	1.5 2.1 3.1 3.4
10. Awning will not roll up	Rafters Cam Black adjustment knob Torsions	1.8 2.9 1.9 2.8
11. Awning will not stay in rolled down position	Cam	2.9
12. Awning billows out when traveling down the road	Cam	2.9
13. Awning stops at guard when rolling up	Rafters Stop plug Operation Torsions Awning rail Top mounting brackets	1.8 1.7 3.2 2.8 4.3 1.5

SYMPTOM	CAUSE	REFER TO
14. Water leaks through guard	Operation Guard Tube deflection	3.3 2.5 2.6
15. Water drips down the side of coach	Awning rail Rubber seal	4.1 2.7
16. Water leaks through fabric	Fabric	2.11

SECTION 1 HARDWARE COMPONENTS

1.1 NUTSERT OR SPECIAL NUT

The **nutsert** is simply a threaded fastening device used to tighten down the black adjustment knob. If the knob will not tighten, first remove the secondary rafter assembly from the hardware. Turn the knob to determine if the nutsert is stripped or spinning. If so, replace the nutsert. If you cannot turn the knob it will be necessary to replace both the nutsert and the black adjustment knob.

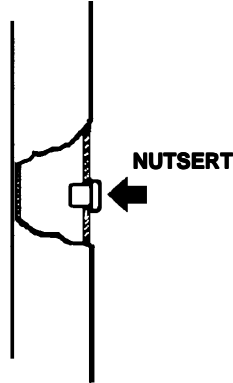

On some arm assemblies the nutsert has been replaced with a **SPECIAL NUT**. If the knob will not tighten, first separate the rafter assembly. Turn the knob to determine if the special nut is stripped. If so, replace the special nut. If you cannot turn the knob, it will be necessary to replace both the special nut and the back adjustment knob.

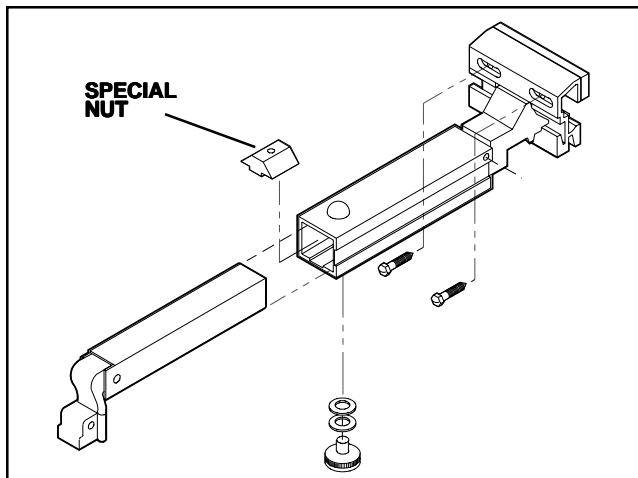

NOTE: The special nut could be a large hex nut as well as the one shown.

1.2 WASHER STACK-UP

Washer stack-up merely means the proper positioning of the washers on the stud of the black adjustment knob. Remove the knob and check for proper washer position. The plastic washer should be against the main rafter, and backed by the metal washer for stiffness. If the stack-up is not proper it should be corrected.

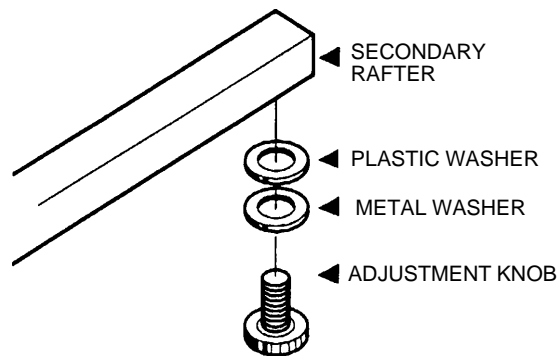

1.3 PUSH BUTTON ASSEMBLY

The push button assembly locks the main support arm to the adjustable arm assembly and controls the height of the awning in the open position. To check it, open the awning to full extension. Look inside the main support arm, and activate the push button to see if the locking pin is moving in and out of the hole in the adjustable arm assembly. If the locking pin does not move, or has been

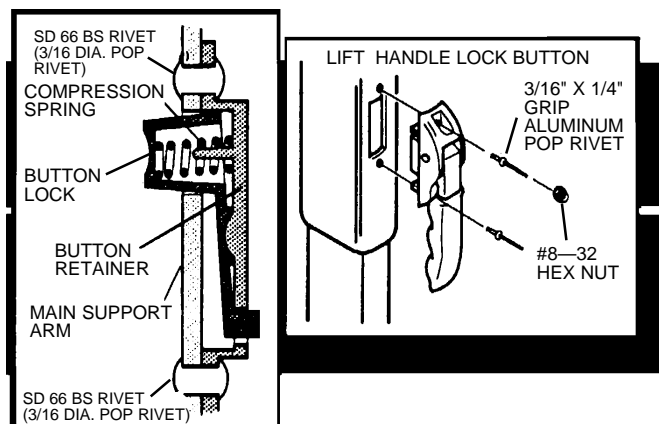

broken off, the push button assembly must be replaced. At times the lock pin of the push button assembly can break off and jam between the push button housing and the adjustable arm assembly, making it difficult to extend the main support arm.

1.4 ADJUSTABLE ARM ASSEMBLY

The adjustable arm assembly allows for telescoping height adjustment of the main support arm, and it connects to the bottom mounting bracket to support the weight of the awning. If the main support arm cannot be extended freely, the adjustable arm assembly should be checked. Remove the adjustable arm assembly and check for nicks, burrs, bends or twists. If any deflection is noted, the adjustable arm assembly must be replaced. For ease of operation apply GO-EASY, a special lubricant.

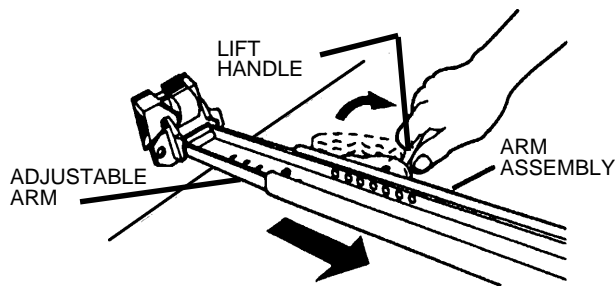

NOTE: GO-EASY is available from your distributor.

1.5 TOP MOUNTING BRACKETS

The top mounting bracket supports the main rafter assembly to hold the awning in the open extended position, and allows the rafter to pivot into the "C" channel of the main support arm. Each top mounting bracket should be mounted directly over the awning rail so the screws go through the "C" portion of the rail.

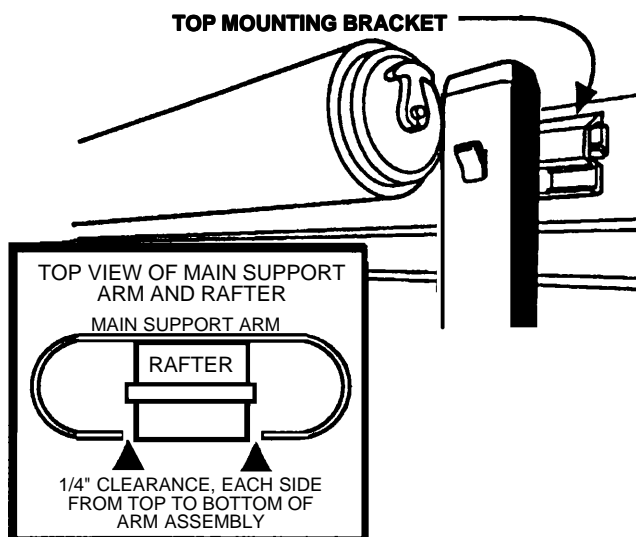

On the Series 9000 awning the top mounting bracket can be mounted lower when possible. If the top mounting bracket is mounted above center of the awning rail, the aluminum guard may not cover the fabric completely in the closed position. If this is the case, relocate the top mounting bracket accordingly.

The top mounting brackets have slotted holes for the mounting screws, allowing them to be adjusted side to side. To adjust the brackets, close the awning and sight down the main support arm and the main rafter. The clearance on each side of the rafter should be approximately 1/4 inch. If clearance is not appropriate, adjust the top mounting bracket(s) as necessary.

1.6 BOTTOM MOUNTING BRACKETS

The bottom mounting brackets are screwed to the floor line of the unit, and they support the weight of the awning. They also provide a quick release to set up the awning in the patio

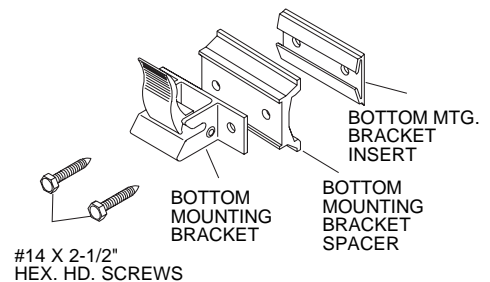

position. If a bottom mounting bracket settles, sags, or becomes loose it can reduce the clearance between the top casting of the torsion and the extension of the top mounting bracket, making operation difficult. Check the bottom mounting bracket for looseness or settling, and tighten or reposition it accordingly for proper operation.

1.7 STOP PLUG

The stop plug is a mechanical stop that supports the main arm when opening and closing the awning. It controls the clearance between the top casting of the torsion to the extension of the top mounting bracket. This clearance should be 1/4 inch to 1 inch. To adjust the clearance, raise or lower the stop plug as needed. On the 9000 and 9500 Series awning the clearance should be kept to a minimum for best operation.

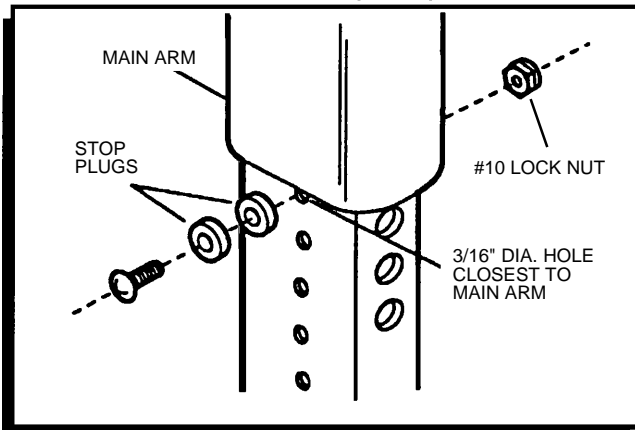
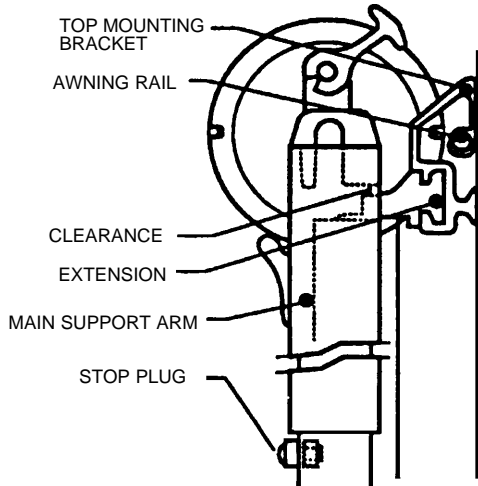

1.8 RAFTERS

The rafters telescope from the top mounting brackets to the main support arms to provide tension on the fabric in the full open position. If the rafters are bent or twisted, this will hinder the operation of the awning. Open the awning and remove the secondary rafter from the main support arm. Now sight down the main and secondary rafters and check for any bends, twists or deflection. If one or the other rafter is not true it should be replaced.

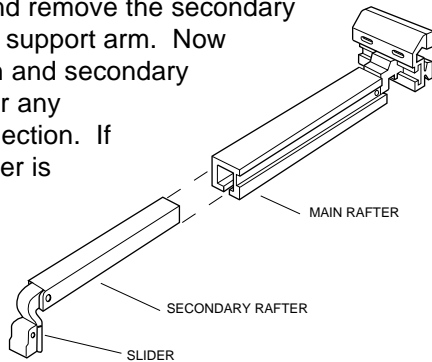

1.9 BLACK ADJUSTMENT KNOB

The black adjustment knob tightens the secondary rafter to the main rafter to keep the fabric taut in the full open position. When closing the awning, the knob should not be tightened down until after the awning is rolled up and the travel lock is engaged.

Attempting to open the awning without first loosening the black adjustment knobs can damage the slider of the secondary rafter, making it difficult to open the awning.

SECTION 2
FABRIC ROLLER TUBE ASSEMBLY (FRTA)

2.1 POSITION

For the awning to operate properly the fabric must be positioned properly in the awning rail and on the roller tube. Open the awning and check the position of the fabric between the top mounting brackets. If the fabric is not centered, remove the tek screws, center it, and replace the screws.

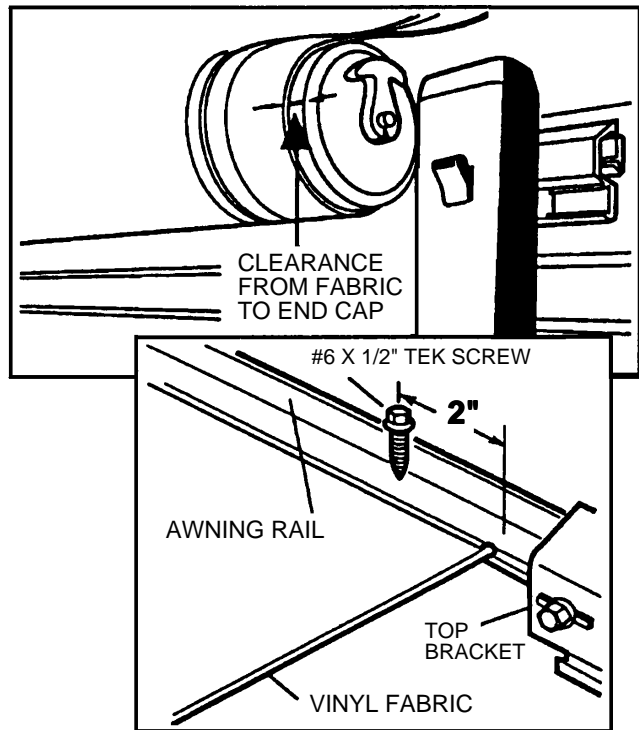

When the fabric is properly positioned, next check the position of the fabric on the roller tube. The clearance from the end cap of the torsion assembly to the edge of the fabric must be the same on each end. If it is not, adjust the fabric on the tube as necessary. On the Elite 9000 and 9500 awning the fabric is held in place to the weatherguard with 1/8" pop rivets. Check the position of the fabric at each end of the weatherguard. If the fabric has shifted, remove the pop rivets, center the fabric and re-rivet.

2.2 SQUARE

If the fabric on the awning is out of square, it could cause the fabric to telescope in one direction when rolling up, or to not hang properly in the open position.

To check fabric for square, measure from the top right hand corner of the fabric (not the weatherguard) to the bottom left hand corner at the poly rope. Now measure from the top left hand corner to the bottom right hand corner as shown below.

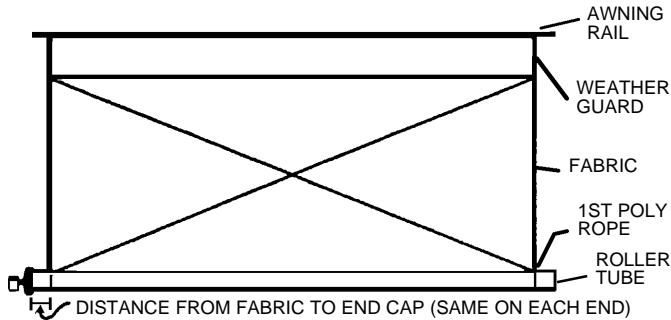

In this check, the difference of the two dimensions should be no more than one inch. If it is more, the fabric is out of square, and replacement would be necessary.

2.3 WEATHERGUARD

The weatherguard is the last 15 inches of the awning that encloses the fabric in the rolled up position. It protects the striped fabric from the environment and elements. The weatherguard is a heavy 17 oz. vinyl fabric.

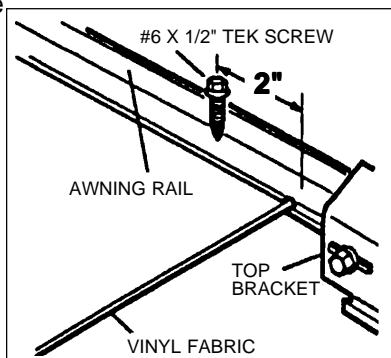

When the vinyl weatherguard or fabric has excessive wrinkles, it will be necessary to stretch the weatherguard or fabric. Open the awning and allow the fabric to warm up. Remove one Tek screw, grasp the weatherguard, stretch it, and resecure the screw. Repeat this procedure for the other end, making sure to stretch each side an equal distance, keeping the fabric centered between the top mounting brackets. Close and reopen the awning three times. If wrinkles are still present, repeat the above stretching procedure. This may have to be done 4 or 5 times before all wrinkles disappear.

2.4 SEAMS

The seams of the vinyl awning are electronically welded together with a heat seal. The welded seams are the strongest part of the fabric. If the fabric has wrinkles or sags, it may be due to improper seam welding. A close inspection may reveal the seams to be the source of the problem. If so, fabric replacement would be needed. Whenever wrinkles are detected in the fabric, stretching of the weatherguard should be performed before the fabric is condemned for bad seams. See 2.3 for stretching instructions.

2.5 ALUMINUM GUARD

The aluminum guard on the Elite 9000 and 9500 is the last 15 inches of the awning that encloses it in the rolled up position, and protects the woven acrylic fiber fabric from the environment and elements.

On 9000 awnings that have the hinge slat which fits into the awning rail:

When the awning is fully extended, the aluminum guard should have an arch of at least 2 inches. The arch helps water to run off rather than between the sections of the guard.

NOTE: The aluminum guard is not waterproof.

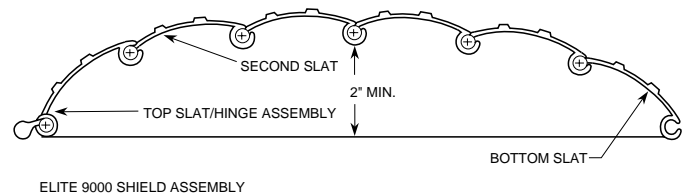

To check the aluminum guard for proper arch, open the awning to full extension, making sure the fabric is taut. Hold a flat edge to the bottom of the guard and measure from the flat edge to the inside of the arch at its highest point. If the measurement is less than 2 inches, the guard should be replaced.

On both 9000 and 9500 awnings that DO NOT have the hinge slat:

The arch of the aluminum guard is not important as the fabric goes under the aluminum guard and attaches the awning to the awning rail.

2.6 ROLLER TUBE

9000 WITH HINGE SLAT

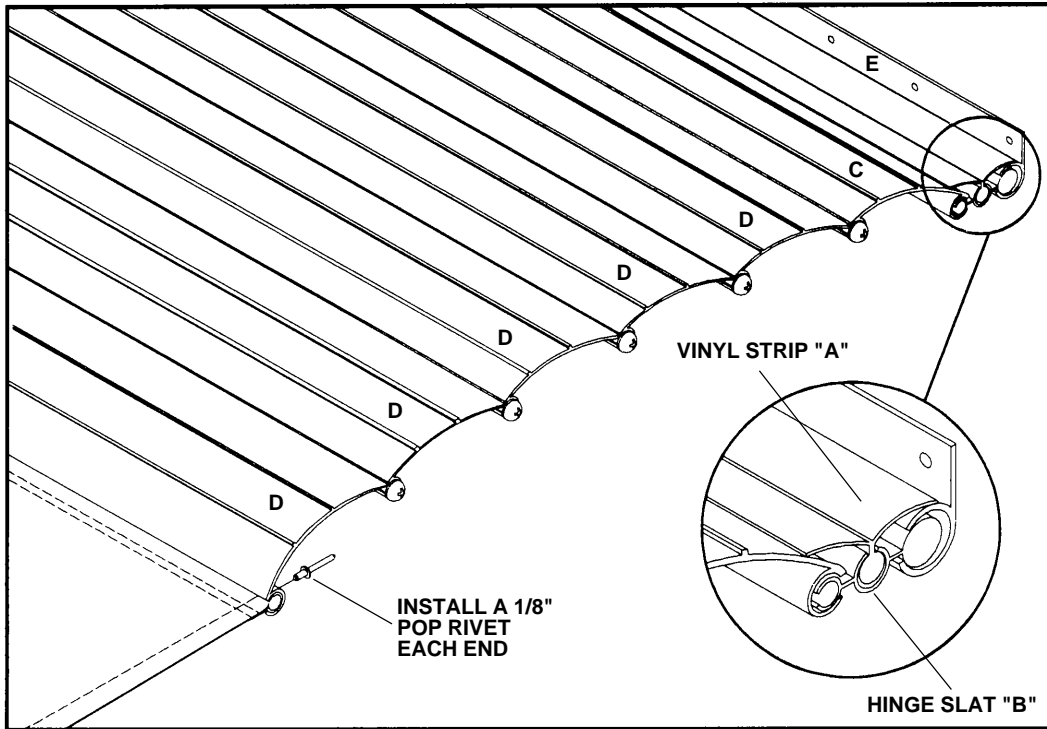

- A - VINYL STRIP**
- B - HINGE SLAT**
- C - TOP SLAT**
- D - MAIN SLAT**
- E - AWNING RAIL**

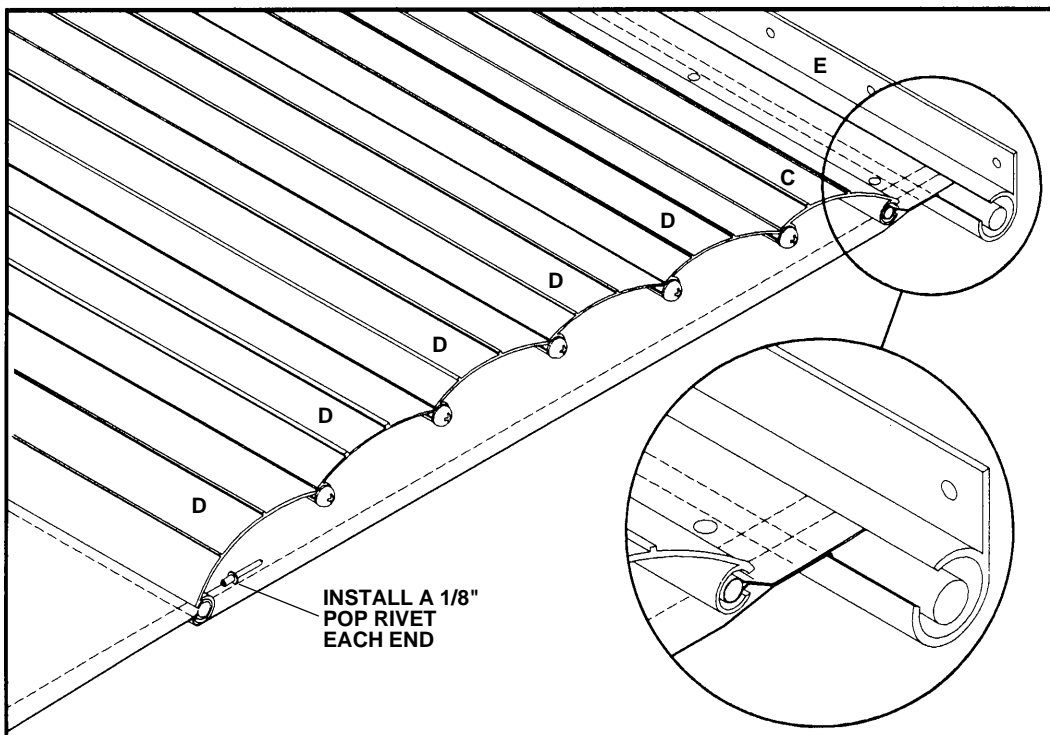

TOP SLAT "C"
VIEW RH END

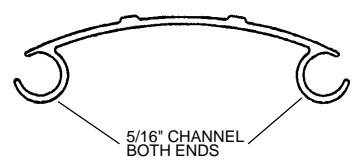

MAIN SLAT "D"
VIEW RH END

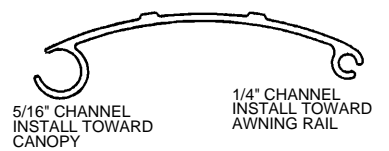

HINGE SLAT "B"



VINYL STRIP "A"



9000 AND 9500 WITHOUT HINGE SLAT

The roller tube is a 3-1/2 inch diameter tube. It has three symmetrical grooves to retain the poly ropes of the awning fabric.

If the fabric appears to have more than normal sag, the roller tube deflection must be taken into consideration. Depending on the length of the awning, the roller tube can deflect from one to five inches with the awning in the open position.

Installing a tension rafter will usually remove 80 per cent of sag and roller tube deflection. All awnings 22 feet and longer should be installed with heavy duty hardware which includes a center tension rafter, a center supporter, and heavy duty adjustable arm assemblies.

If the roller tube is bent, it will bounce up and down when opening and closing the awning. On the 9000 Series this can cause the aluminum guard to leak, because the guard assembly may not be tight.

2.7 RUBBER SEAL

On the 9000 Series awning(see Section 2.5), an extruded black rubber seal is located at the awning rail of the coach. The seal slides into the metal hinge which connects the aluminum guard to the awning rail. This seal is designed to prevent water from running down the side of the coach.

To check, inspect the full length of the seal for proper positioning, and for cuts, tears or wrinkles. If any of these problems are found, the seal should be repaired or replaced.

On some units it may be necessary to silicone seal the lips of the rubber seal to the awning rail and the top slat of the aluminum guard as shown , to prevent water from running down the side of the RV.

2.8 TORSION

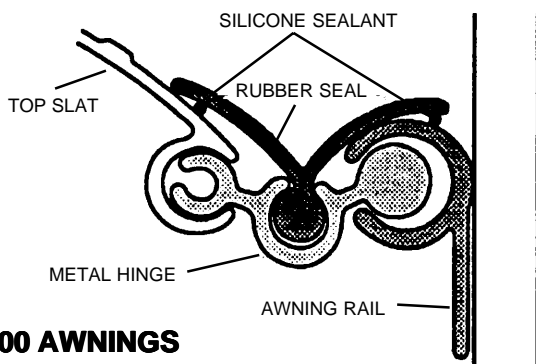

**9000 AWNINGS
WITH HINGE
SLAT**

The torsion assembly has a wound coil spring which

provides tension on the roller tube to roll the awning up into the travel position.

The right hand torsion end cap contains a cam assembly which prevents the awning from billowing or unrolling during travel. It also allows one-person set-up of the awning by preventing rollback.

When difficulties are experienced in rolling the awning up, the tension on the torsion should be checked. In

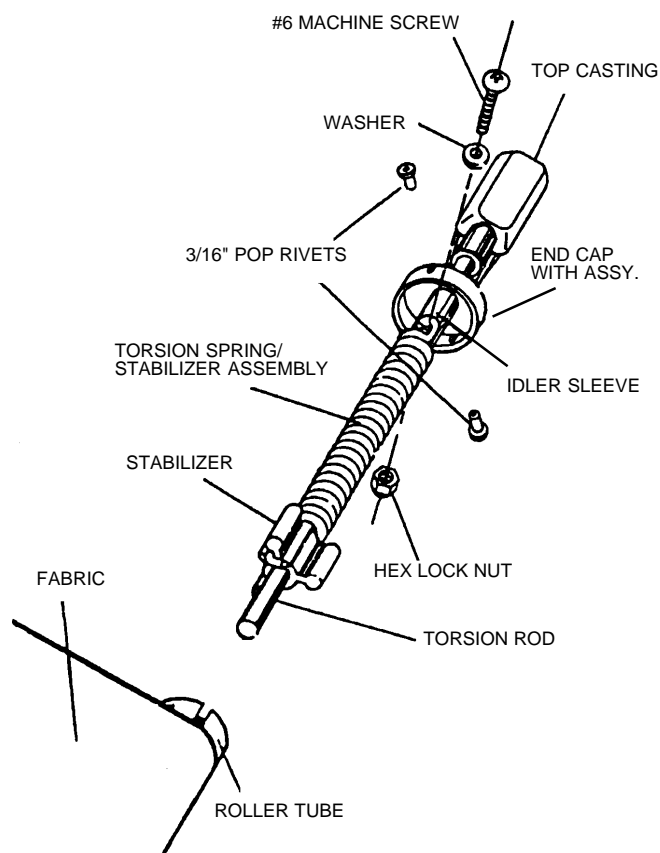

most cases adding a few turns of torque to each end will correct the problem. If all tension has been lost, refer to the following chart and apply the specified number of turns as indicated. This must be done with the awning extended two feet away from the coach.

! WARNING

TORSION ASSEMBLY TORQUE SPECIFICATIONS				
Awning Length (Ft.)	Number of Turns			
	MODEL NUMBER			
	5000	7000	7500 8000 8500 9000	9500 Grande Pavillion
8	6	-	8	-
9	6	-	8	-
10	6	8	8	-
10' 8"	6	8	8	-
11	6	8	8	-
12	6	8	8	-
13	7	9	9	-
14	7	9	9	-
15	8	10	10	-
16	8	10	10	6
16'6"	-	-	12	-
17	10	12	12	6
18	10	12	12	7
19	11	13	13	7
19'6"	-	-	13	-
20	11	13	13	-
21	11	13	13	8
22	12	-		8
23	12	-		8
24	12	-		9
25	12	-		9

SPRING IDENTIFICATION CHART		
	Standard	Heavy Duty
Wire Dia.	.120	.140
RH	Painted red cap end and no paint on stabilzier end.	Painted red cap end and white on stabilzier end.
LH	No paint on either end.	Painted white on cap end and no paint on stabilizer end.
Length	TURNS OF TENSION	
22'	14	8
23'	14	8
24'	14	8
25'	14	8

 See Spring Identification Chart for No. of Turns

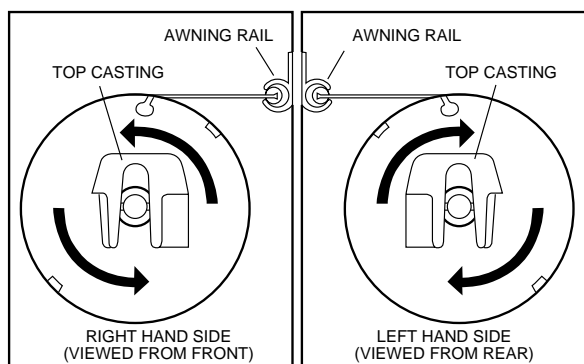

When winding the torsion, be sure to wind in the proper direction.

SEVERE INJURIES CAN RESULT FROM THE SPINNING TOP CASTING. USE VISE GRIPS® (NEVER BARE HANDS) TO GRASP TOP CASTING WHILE LOADING TORSION.

Note: Rewinding must be done with the Awning Fabric extended two feet away from the coach.

2.9 CAM

The cam assembly locks the roller tube from turning in

one direction or the other according to which way the cam lock lever is flipped.

To check the cam lock on the A&E awning, unlock the main support arms. Hook the pull rod into the pull strap and try to open the awning. Be sure the cam lock lever is in the roll-up position. If the roller tube rotates 1/2 turn or more the cam lock must be repaired or replaced.

To check the roll-down position of the cam lock, open the awning to full extension. Grasp the roller tube with your hands and try to turn the tube in the direction it will roll up. If the tube can be rotated 1/2 turn or more the cam lock must be repaired or replaced.

2.10 STITCHES

The side hems and poly ropes of the awning are stitched in with a sewing machine. At times the stitches can allow water to leak through to the inside of the roller tube. On vinyl awnings the stitches should be sealed with seam sealer, available at sporting goods stores. This will stop the water from running down the inside of the roller tube. For the woven acrylic fabric of the 9000, 9500 Series awning, Acrylife is an approved sealant.

When sewing in the poly ropes of the fabric, if a straight line is not followed it could cause the fabric to hang

improperly. A close inspection of the stitching could reveal the cause of a sag or pucker.

2.11 FABRIC

A. 9000 AND 9500

The awning fabric is woven acrylic, not vinyl. It is water resistant but not waterproof. Once a year it should be cleaned with Canopy-Clean and resealed to maintain its water resistance. Acrylife is an approved sealant for the 9000, 9500 fabric. Follow the directions for application of Canopy-Clean and Acrylife.

NOTE: Avoid touching the underside of the awning fabric when it is wet, as this breaks the surface tension of the water causing it to seep through.

B. 8500 AND GRANDE PAVILLION

The awning fabric is vinyl. It is waterproof. Once a year it should be cleaned with Canopy-Clean and treated with Vinyl Formula 201 to protect and extend the life of the fabric. Follow the directions for application for Canopy-Clean, and Vinyl Formula 201. Contact your distributor for these products.

2.12 TEK SCREWS

The Tek screws are the two screws installed through the awning rail of the coach. They keep the aluminum guard from shifting in the awning rail. On vinyl and some acrylic awnings (see Sec. 2.5) they keep the fabric from shrinking with age. If one Tek screw is missing, the fabric will pull toward the remaining Tek screw causing the fabric to wrinkle.

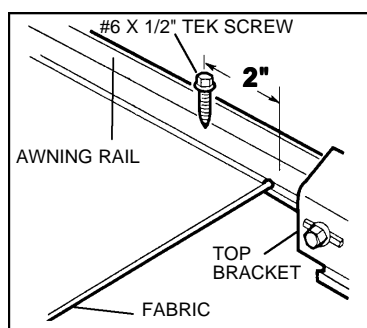

SECTION 3 OPERATION

3.1 PULL STRAP

When closing the awning the pull strap must be rolled up at an angle from the center of the roller tube. This will keep the awning from telescoping forward or rearward, and will prevent a bulge from forming in the area where the strap is rolled up.

If the pull strap is rolled up at one end of the awning, it can cause the fabric to telescope in that direction during roll-up, and create a bulge or wrinkles at that end. This could cause the awning arm to stay against the side of the coach when trying to open.

3.2 CLOSING

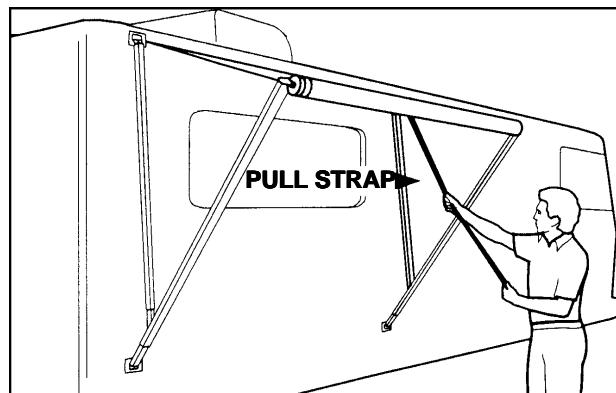

On the 9000 and 9500 Series, when rolling up the awning, the roller tube assembly should not be slowed down before reaching the aluminum guard. This could cause the roller tube to stall at the guard.

3.3 TAUTNESS

On 9000 Series awnings that utilize a hinge slat (see Sec. 2.5): To minimize water leakage through the aluminum guard, the fabric must be taut when the awning is extended. This will keep the sections of the aluminum guard tight against each other. Before tightening the black adjustment knob, be sure to apply enough downward force on the main support arm to pull the fabric taut.

3.4 TRAVEL LOCK

The travel lock must be fully released before trying to open the awning.

SECTION 4

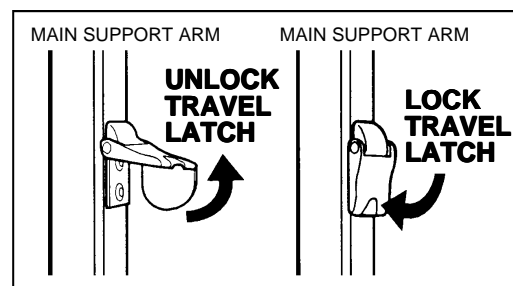

AWNING RAIL

4.1 LEAKAGE

When water drips down the side of the coach, the seal between the coach and the awning rail must be checked. If improper seal is detected, reseal the awning rail.

4.2 STRAIGHT

Before condemning the fabric for sags or wrinkles, the awning rail should be checked. Open the awning and sight down the rail to see if the rail or sidewall varies up, down, inward or outward. This must be taken into consideration when checking a fabric.

4.3 TYPE

There are three types of awning rail used in the RV industry. Of these, type A and B (see below) are acceptable for use on the 9000 Series awning that utilizes a hinge slat (see Sec.2.5) . Type C should never be used on the 9000 Series that utilizes a hinge slat (see Sec. 2.5) as it could cause a binding problem on the aluminum guard assembly, but it is acceptable on the vinyl awnings.

